

Bill of Materials		
Part #	Description	Qty
M02850	Body Mount	2
M03551	Body Mount	2
M02787	Body Mount	4
M02845	Body Mount	4
M03550	Bed Mount	2
S10126	Washer 2 1/2"	8
S10128	Washer 1 1/4"	6
S10138	Washer 1 1/2"	6
S10203	Nut 7/16	6
S10114	Nut 5/16"	2
S20318	Bed Bolt 12 x 50mm	6
S20320	Bolt 7/16 x 4 1/2"	4
S20319	Bolt 7/16 x 5"	2
S20321	Bolt 5/16 x 2"	2
S10129	Steel Tubing 3 3/8"	4
S10012	Steel Tubing 2 1/4"	2
S10775	Bed Tubing Spacer	6
S10321	Cab Bracket	4
S10776	Steering Coupler	1

### Cab Installation

- RADIATOR FAN SHROUD:** Only raise body high enough to remove and replace body mounts. Always watch the fan shroud for sufficient clearance when raising the body.
- Remove the 12mm bolts and nuts from the upper steering coupler on the rack and pinion noting the position of the steering column. Note: do not let the steering column turn, keep the column and rack aligned to its original position, mark if necessary. See figure 2.
- Loosen body mount bolts on the driver's side of vehicle and remove bolts from opposite side for positions 1,2 and 3, see Figure 1. Place a 2x4 between the jack and body to spread out load.
- Raise the body on the driver's side just far enough to remove mounts. Temporarily prop up the cab between cab and the frame with a wooden 2x4 or spacer. (This is to avoid cab from falling while working on body mounts.) The bolts on the opposite side will help ensure that the body does not shift. Make sure cab doesn't contact bed when lifting.
- Remove factory mounts one at a time.
- Install the new S10321 steel bracket, polyurethane body mounts, and steel sleeves in positions 1, 2 and 3. Refer to the diagrams for positions. NOTE: On 2001 and newer models you will need to invert the #2 position bushings so that the M02787 is on top.
- Install the supplied aluminum steering coupler with the round bosses pointing down. Note: you may have to loosen the pinch bolt at the top of the steering coupler so that it will slide up enough to install the steering coupler. See figure 2.
- Lower the driver's side and START the new bolts into the new mounts. Reconnect the steering coupler with the supplied 5/16" bolts from the top and nuts. DO NOT TIGHTEN!
- Now remove bolts from passenger side of vehicle and repeat steps 3 through 6.
- Tighten the steering coupler bolts and nuts to 35ft lbs also tighten the upper steering bolt to 35ft lbs.

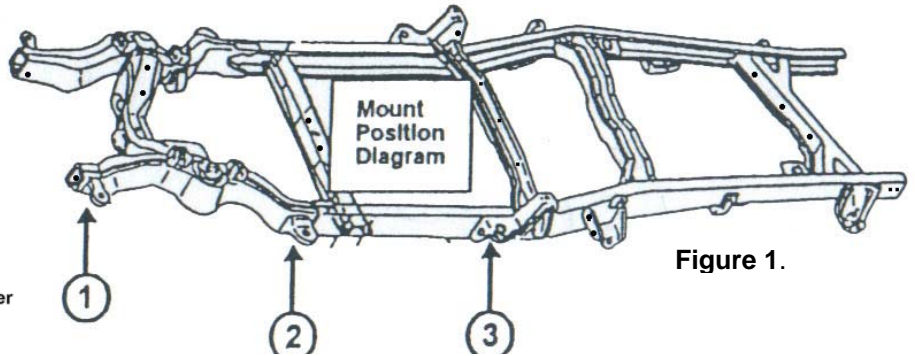
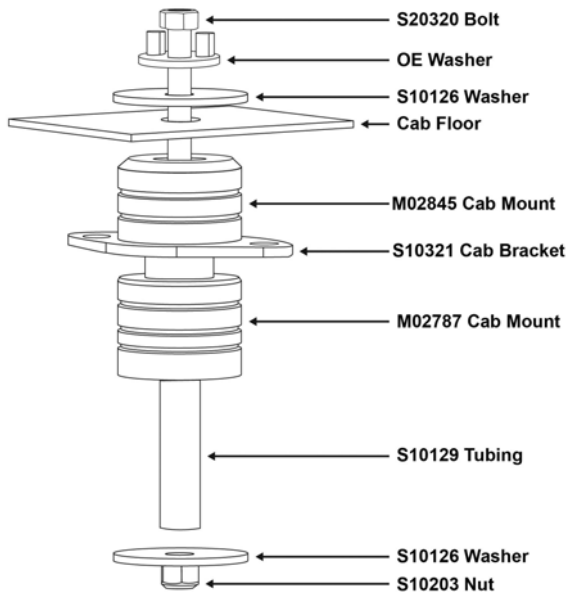
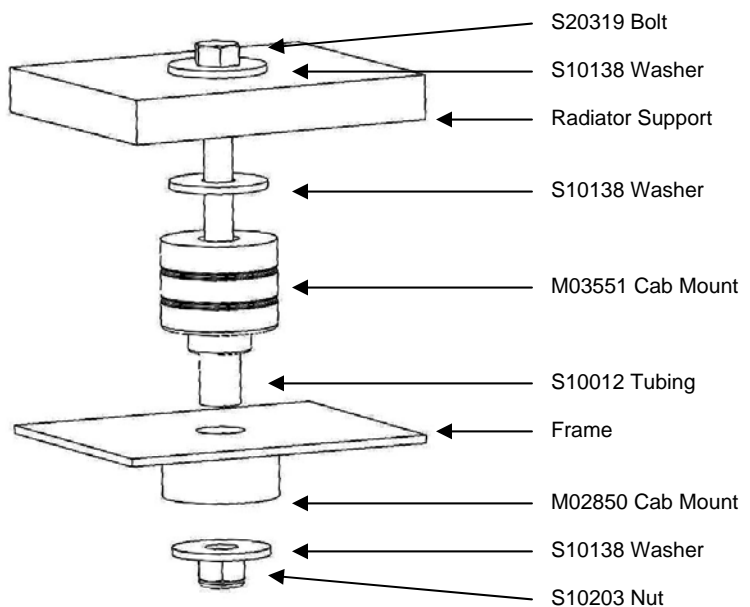

Figure 1.



Positions 2 & 3



Position 1

### Bed Installation

1. Loosen the 6 bed mount bolts. Remove 3 bolts from one side. Place a 2x4 between the jack and bed to spread out load.
2. Raise the bed on the side you have removed the bolts from just far enough to install the rectangular steel tube bed spacers and start the new supplied 12mm bolts. The bolts on the opposite side will help ensure that the bed does not shift. See figure 3.
3. Install the rectangular polyurethane bed spacer on to the bed, sliding the clip into the bed rail support near the tire. See figure 4.
4. Remove bolts from other side of bed and repeat steps 2 and 3.
5. Once all new mounts are in place, align the bed with the cab. Re-torque all bolts to 60ft lbs, DO NOT over tighten bolts.
6. Before starting engine, check fan for clearance from fan shroud and make sure all lines and wires are free and clear.

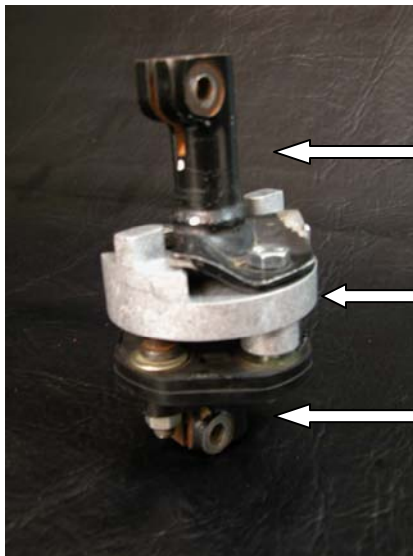

OE Upper Steering Coupler to column.  
S10776 Aluminum Steering Coupler  
OE Lower Steering Coupler on Rack & Pinion

Figure 2.

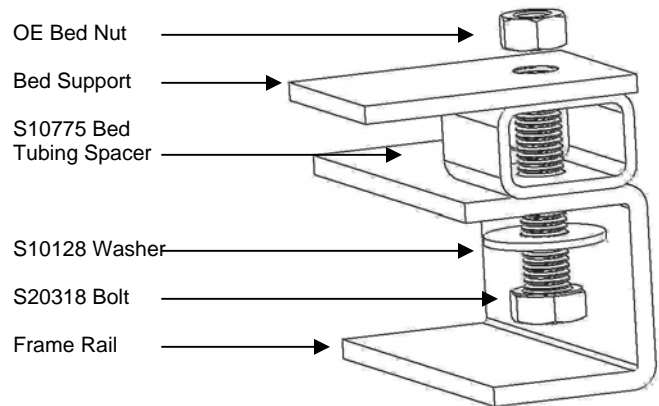

Figure 3.

Insert rectangular polyurethane bed spacer in wheel well onto bed support.



Figure 4.

### WARNING

This vehicle has been modified to enhance its performance. The steering, braking and handling of this vehicle will differ from standard passenger cars and trucks. This vehicle handles differently from an ordinary vehicle in driving conditions which may occur on streets, highways and off road. Avoid unnecessary abrupt maneuvers, sudden stops, sharp turns and other driving conditions that could cause loss of control, possibly leading to a roll over or other accident that could result in serious injury or death to driver and passengers. If larger tires are installed the speedometer will read lower than the vehicles actual speed.

**DRIVE WITH CARE, REDUCE SPEED AND WEAR SEAT BELTS AT ALL TIMES.**

*This kit should be installed by a professional mechanic.*